



ZR6FD logo

Drukwerk  
printing  
ZS6BAQ

Papier / Paper  
Richard ZS6UK  
Bill ZS6KO  
Deryck ZS6KQ

# WATTS

09 - 2007

Year 77+9m

Monthly newsletter of the Pretoria Amateur Radio Club  
Maandelikse nuusbrieff van die Pretoria Amateur Radio Klub.



PARC, PO Box 73696 Lynnwood Ridge 0040, RSA



<http://www.zs6pta.org.za> mail:[zs6pta@zs6pta.org.za](mailto:zs6pta@zs6pta.org.za)

Bulletins :145,725MHz 08:45 Sundays / Sondae

Relays : 1840, 3700, 7066, 10135, 14235, 51400, 438825, 1297000kHz

Activated frequencies are announced prior to bulletins

Swapshop: Live on-air after bulletin 2m and 40m

Bulletin repeats | herhalings : Mondays 19:45 on 145,725 MHz



PRETORIA SECTION S.A.R.L. 1929

R.H. Borchers (listener), ZS6V "B.J." Nyenhuis, ZU6R Len Nicholson, ZU6B Fraser Alexander, ZS6AH "Viv" Hicks, ZU6M "Brian" Scallan, B. Van Heerden  
ZU6K "Ronny" Levy, ZU6E "Wally" Browning, ZS6AF "Bill" Lister, ZT6W "Watty" Watson, (SABC Engineer, Pretoria),  
ZU6L "Tommy" Laxton, ZU6D F.H. Connolly, ZU6N "Nellie" de Kock.

## In this issue

- Minutes Aug 4
- Editorial
- Member news
- HAMNET what you wanted to know Wat u wou weet van HAMNET
- Technical
  - Printed circuit origins
  - Airline cellphone bans
  - Matching a Folded dipole
- Page eight

## In hierdie uitgawe

- Notules
- Redaksioneel
- Ledenuus
- Tegnies
- Bladsy agt

## Next Meeting

**1 Sept 2007**

Time: 13:30 for 14:00  
PARC Clubhouse  
South Campus  
University of Pretoria  
SE cnr University and  
Lynnwood roads.

## PARC Management team / Bestuurspan Aug 2006- Sept 2007:

Committee members					
<b>Chairman,</b> SARL liason, Fleamarkets	Alméro Dupisani	ZS6LDP	<a href="mailto:chairman@zs6pta.org.za">chairman@zs6pta.org.za</a>	012-567-3722	082-908-3359
<b>Secretary, Vice Chairman</b> Rallies, Social, Hamnet	Johan de Bruyn	ZS6JHB	<a href="mailto:secretary@zs6pta.org.za">secretary@zs6pta.org.za</a>	012-803-7385	082-492-3689
<b>Treasurer,</b> Database, DF hunts	Richard Peer	ZS6UK	<a href="mailto:treasurer@zs6pta.org.za">treasurer@zs6pta.org.za</a>	012-333-0612	082-651-6556
<b>Public relations</b>	Craig Symington	ZS6RH	<a href="mailto:pro@zs6pta.org.za">pro@zs6pta.org.za</a>	083-259-3233	083-259-3233
<b>Repeaters, Technical</b>	Craig Symington	ZS6RH	<a href="mailto:technical@zs6pta.org.za">technical@zs6pta.org.za</a>	083-259-3233	083-259-3233
Co-opted / Geko-opteer:					
<b>Repeaters, technical</b>	Johan Lehmann	ZS6JPL	<a href="mailto:jlehmann@csir.co.za">jlehmann@csir.co.za</a>	012-804-6173	083-300-8677
	Hans Gurtel	ZR6HVG	<a href="mailto:adele123@absamail.co.za">adele123@absamail.co.za</a>	082-940-0623	082-940-0623
	Pieter Human	ZR6AHT	<a href="mailto:humanp@telkom.co.za">humanp@telkom.co.za</a>	012-800-2888	082-565-6081
<b>Auditor</b>	Position open				
<b>Newsletter/Kits</b>	Hans Kappetijn	ZS6KR	<a href="mailto:editor@zs6pta.org.za">editor@zs6pta.org.za</a>	012-333-2612	072-204-3991
<b>Asset control</b>	Andre v Tonder	ZS6BRC	<a href="mailto:andre.vtonder@absamail.co.za">andre.vtonder@absamail.co.za</a>	361-3292	082-467-0287
<b>Tydrenne/Rallies</b>	Johann de Beer	ZR6YV		011-918-1060	082-857-1561
<b>Klubfasiliteite, vlooiemark</b>	Willie Greyling	ZR6WGR	<a href="mailto:willie@up.ac.za">willie@up.ac.za</a>		082-940-2490
<b>Webmaster</b>	Edwin peer	ZR6ESP	<a href="mailto:zr6esp@peer.co.za">zr6esp@peer.co.za</a>	012-333-0612	
<b>Hamnet, projects</b>	Roy Newton	ZS6XN	<a href="mailto:newtonr@telkomsa.net">newtonr@telkomsa.net</a>	012-547-0280	
<b>Historian/Awards</b>	Tjerk Lammers	ZS6P	<a href="http://zs6p@iafrica.com">zs6p@iafrica.com</a>	012-809-0006	
<b>Public Relations</b>	Jaco Lubbe	ZR6JLL			082-494-1959
	Thobile Koni	ZS6TKO	<a href="mailto:toko40@mweb.co.za">toko40@mweb.co.za</a>		082-493-2483
<b>Tea</b>	Molly Peer	ZR6MOL	<a href="mailto:molly@peer.co.za">molly@peer.co.za</a>	012-333-0612	
	Doreen de Bruyn	ZR6DDB		012-803-7385	

## Minutes of the monthly club meeting of the Pretoria Amateur Radio Club held at the South Campus of the University of Pretoria on 4 Aug 2007

**Welcome:** The Chairman welcomed all present.

**Present:** As per club register.

**Apologies:** Johan ZS6JHB, Pieter ZS6PVW, Magda ZS6MVW and Lizette ZS6LZT.

**Minutes:** The minutes of the previous meeting were published in Watts and taken as read. Proposed by Brian ZR6BJS and seconded by Hans ZS6KR.

### Club Activities

**QSL Cards:** Richard ZS6UK confirmed with the Bureau, but has been unable to reach Chris ZS6BGH.

**Rallies:** Johan ZS6JHB and several members are away on the Witbank rally.

**Fox Hunts:** These will be on hold until September.

**Social:** The bring and braai after this meeting was cancelled due to lack of interest. It was noted that there will be a bring and braai after the meeting on 1 September.

**Projects:** Roy ZS6XN was not present. He is working on a few projects.

**Flea Market:** The PARC winter flea market will be held on Saturday 29 June at the south campus of the University starting at 08:00. Magda ZS6MVW and family will be doing the usual eats and Richard ZS6UK will be doing the cool drinks. The PARC AGM will be held from 11:00 on the same day after the flea market. Members intending to attend should advise Johan ZS6JHB of numbers for reason of catering for the social afterwards.

**Ham Diary:** The ham diary from the SARL web pages was presented.

**Interference:** Jaap Lourens from Sentech is an amateur with the authority to stamp out noise, and assisted Hans to stop interference from a neighbour's electric fence.

**Next Meeting:** The next meeting will be on August 1 starting at 14:00.

## What is being done to improve immunity to electronic equipment?

(found on SARL website)

The European Commission (EC) has issued a directive (89/336/EEC) on "Electromagnetic Compatibility" (EMC). This term means that one piece of electronic equipment such as a radio or TV can be used near another piece of electronic equipment such as a radio transmitter and neither one causes unwanted effects on the other.

The EC Directive applies to almost all electronic equipment manufactured after 1992. This includes commercial and industrial equipment as well as consumer goods such as radios, TVs, video recorders, home computers, telephones, burglar alarms, microwave ovens and washing machines.

This has a spin-off effect for South Africa. The South African Bureau of Standards has adopted the European standards on electromagnetic compatibility which means that equipment sold by the reputable manufacturers who subscribe to the SABS standards will comply.

Although there have been many advances in electronics in recent years, not enough attention has been paid to EMC. Equipment such as the types listed above may not work properly near a radio transmitter or may interfere with radio and TV broadcasts or other radio communication.

## Editorial – AGM coming up

30 days left before our 77<sup>th</sup> Annual General Meeting and I wonder who is prepared to make him/herself available to perpetuate the club into year 77-78.

It is imperative that management and membership remain as strong as before and this requires serious self-examination if a little personal sacrifice can be made for the good of the club.

Note the last paragraph of the adjacent 1951 report!

## Redaksioneel – AJV nader

30 dae is oor voor ons 77e AJV plaasvind en ek wonder wie hom/haar wil beskikbaar maak om die klub voort te sit vir die bestaansjaar 77-78. Dit is noodsaaklik dat die bestuur en lidmaatskap net so sterk bly as in die verlede en dit verlang ernstige self-ondersoek of 'n bietjie persoonlike opoffering ten goede van die klub gemaak kan word. Neem kennis van die laaste paragraaf van die naasliggende 1951 verslag!

## PRETORIA

The prophetic utterance, contained in Pretoria's contribution to last month's issue of Radio ZS, has been fulfilled and, richly draped in laurels, the old committee is now able to sit back and watch us take up the labours it so readily surrendered.

The Pretoria branch held its annual general meeting on the 13th August and elected a new committee for the coming year. As usual competition for the vacant posts was keen and the tension broke slowly as one by one the new victims were pitchforked into their positions. The welcome they received from the old hands who so gallantly stood down for them was truly touching.

Attendance at the meeting was fair. More could have been present but the fear of being elected to the new committee may have kept many of them away. As this danger has now passed we hope to see them at the next and subsequent meetings. Two floating trophies were presented—one to OM Colin Duff, 6AAO, for his work on V.H.F., and the other, for ZSLs, to OM L. S. Metcalf, L6PUB, for his activities as junior ZSL. Congratulations, OMs.

### AGM MOTIONS

**Motions are awaited for consideration by the Committee and AGM. Please submit ASAP before the next Committee meeting in the first week of September.**

### AGM Trophies

**Members that received trophies last year must please return them at our 1 September meeting or hand them over to any Committee member.**

### AGM Braai

**Please notify Johan ZS6JHB of your attendance after the AGM (±lunchtime 29 Sept.) in order that you can receive a braai-pack mahala. Phone or SMS him ASAP. Numbers on p2.**

## Boffins improve capacitors

Seven times better Source: American Physical Society July 2, 2007

BOFFINS AT North Carolina State University physicists have worked out a way to improve high-energy-density capacitors. The new capacitors are more than seven times as effective at handling high energy than the common capacitor.

### High-performance Energy Storage

Science Daily — North Carolina State University physicists have recently deduced a way to improve high-energy-density capacitors so that they can store up to seven times as much energy per unit volume than the common capacitor. High performance capacitors would enable hybrid and electric cars with much greater acceleration, better and faster steering of rockets and spacecraft, better regeneration of electricity when using brakes in electric cars, and improved lasers, among many other electrical applications.

A capacitor is an energy storage device. Electrical energy is stored by a difference in charge between two metal surfaces. Unlike a battery, capacitors are designed to release their energy very quickly. They are used in electric power systems, hybrid cars, and all kinds of electronics.

The amount of energy that a capacitor can store depends on the insulating material in between the metal surfaces, called a dielectric. A polymer called PVDF has interested physicists as a possible high-performance dielectric. It exists in two forms, polarized or unpolarized. In either case, its structure is mostly frozen-in and changes only slightly when a capacitor is charged up. Mixing a second polymer called CTFE with PVDF results in a material with regions that can change their structure, enabling it to store and release unprecedented amounts of energy.

The team, led by Vivek Ranjan, concluded that a more ordered arrangement of the material inside the capacitor could further increase the energy storage of new high-performance capacitors, which already store energy four times more densely than capacitors used in industry. Their predictions of higher energy density capacitors are encouraging, but have yet to be experimentally tested.

Note: This story has been adapted from a news release issued by American Physical Society. <http://www.aps.org>

## Birthdays

## Verjaarsdae

Sept



02 Charell ZR6GN  
02 Lizette ZS6LZT, dogter van Pieter ZS6PVW en Magda ZS6MWW  
05 Bernie ZS6ANU  
09 Brendan, son of Merylyn and Deryck ZS6KQ  
09 Bill ZS6WK  
11 Johan ZS6JPL  
15 Pamela, sw of Harry ZS6HRD  
21 Johan ZS6JHB  
24 Estie ZR6STB  
25 Susan, lv van Freddie ZS6JC  
26 Bokkie ZR6CL  
26 Graham ZR6GJR

Sept

## Anniversaries Herdenkings

02 Lilly and Harry ZS6AMP (51)  
04 Matha Louisa en Attie ZS6REY (38)  
07 Gerda and Roger ZS6RJ (5)  
09 Adele en Hans ZR6HVG (13)  
28 Retha and Roy ZS6XN (22)

26 Pieter ZR6KSA  
27 Lodewyk, seun van Elmarie ZR6AXF en Johan ZS6JPL.  
29 Grant ZR6AAT, son of Merylyn & Deryck ZS6KQ

† Wally Perfect ZS5WP, a long standing PARC member, became SK on 28 July. Our sympathy to his sw May, relatives and friends.

† Our sympathy to Ed ZS6UT who recently lost his mother.

## Sick Parade | Krukkelys

Almero se sw, Louise, sterk weer aan na nog 'n kort hospitaal besoek

Lynnette, daughter of Mary and Bill ZS6KO is recovering well after an operation to join a number of vertebrae.

Craig ZS6RH had a painful encounter with a just-become-mother dog (bitch?) when he came too close?

## Diary | Dagboek (UTC times)

**Aug** 29 **SARL HF CW Contest**  
**Sept** 01 **PARC Club meeting**  
01 SARL@home  
01 West Rand fleamarket  
01-02 IARU region 1 Field Day SSB 1300-1259  
01-02 All Asian DX Contest  
10 Closing date SARL CW logs.  
14-16 SARL VHF-UHF Contest (see rules & times)  
21 Schools close.  
24 Heritage Day.  
**29 PARC fleamarket 8am** local time  
**PARC AGM 11am** local time  
**PARC braai – meat provided only if your name is on the list!**  
30 UBA (Belgium) CW Contest. 0600-1000

### PARC SUBS / LEDEGELD 2006-2007

**Please remit your subs to our treasurer or by transfer to:**

**Betaal asb. u ledegeld aan ons tesourier of per oorplasing aan:**

**Bank : FNB Ordinary members/ gewone lede R70**  
**Branch : 25 20 45 Spouses, pensioners R50**  
**Account : 546 000 426 73**  
**Your call sign must appear as statement text!**

**NB: Only paid-up members can vote at our 29 Sept AGM**

## Snippets | Brokkies

- Recent **paper donations** were received from Bill ZS6KO, Richard ZS6UK and Deryck ZS6KQ. Thanks guys.
- Tjerk ZS6P** is only one short of completing all 337 DXCC entities after getting a recent Swain's Island confirmed. He is hoping for a coup-d'etat (signs of JR Ewing personality?) in Yemen or a government change-of-heart, as this is the only entity forbidding amateur radio and is first on any DXer's the most wanted list.
- Louis ZS6LVW** en familie is nou op pad na die VK vir drie jaar. Daarna Italië. Voorspoed en hoor jou dalk gou op IRLP of HF!
- Johnny ZR6BAJ** sent us a photo of his 10m tower in collapsed format ready for his move to the Cape. Pretty compact!
- As if Saturday Sept 1 is not already fully occupied with Amateur activity, there is also a **rally at Rust der Winter** for which 5 mobile and 6 field stations are required. Phone Johan ZS6JHB if you can assist.
- Reading the mail on our 2m repeater, it seems that **Roy ZS6MI** is hard at work to start VHF / UHF activity. Having made his own antennas, he is still on the lookout for various electronic hardware.
- Johan ZS6JPL** is currently in Bremen, Germany and listens to our bulletins on audio stream. You can call him on Skype (ZS6JPL)





## HAMNET INFORMATION - all you wanted to know.

Contributed by Roy ZS6XN / ZS5HX

### Hamnet Gauteng North Bulletin (weekly)

Monday evenings following the rebroadcast of the PARC Sunday morning bulletin on 145,725 in the Pretoria area.

### Hamnet National Bulletin (monthly)

The Hamnet (National) Bulletin is read at 19H00 on 3:760 MHz on the first Monday of every month.

### Hamnet Weather Watch (daily)

Weekdays at 18H00 local time for the HAMNET Weather Net on 3,760MHz in winter and on 7.060MHz in summer. This net exchanges weather conditions around the country and is also useful as a propagation check.

### SARL Hamnet site

<http://www.sarl.org.za/public/hamnet/hamnet.asp>

### GAREC 2007 – Websites Global Amateur Radio Emergency Communications Conference (GAREC 2007)

<http://www.arri-al.org/GAREC07.htm>

The main emphasis at a recent conference was the use of advanced digital technologies and their applications to emergency communications eg: APRS and D-STAR. South Africa was represented by Francois ZS6BUU.

### Centre of Activity Frequencies.

Francois ZS6BUU will be attending for HAMNET and for SASAR (South African Search and Rescue) by means of a government grant.

### GENERAL Amateur Emergency Communications Websites

<http://www.iaru.org/emergency/> Provides a number of interesting articles and even ITU handbooks on emergency communications

### ARRL

<http://www.emergency-radio.org/> and <http://www.arrl.org/FandES/field/emergency/>

### IARU Region 1 Amateur Emergency Communications Website (EMERCOMS)

<http://www.iaru-r1.org/Emercomms.htm>

---

## Folded dipole matching

from the website of Harry SM0VPO

<http://web.telia.com/>

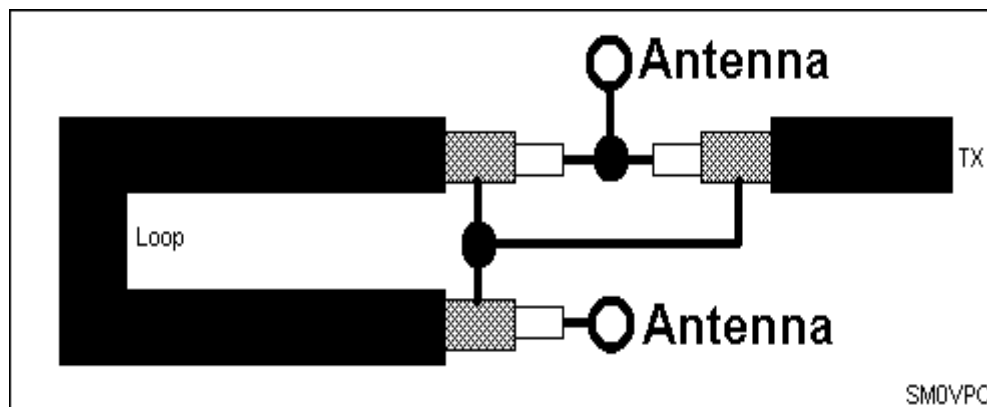

For VHF work the most common balanced antenna is the folded dipole and has an impedance somewhat higher than 50 ohms. A 4:1 balun is the most suitable for feeding balanced antennas at VHF. Ferrites do not perform so well at VHF but a half-wave co-axial cable will do the job. The correct length of the cable loop is cable velocity-factor multiplied by a calculated 1/2 wavelength. This type of balun is quite frequency conscious but the VHF and UHF bands are very narrow, expressed as a percentage of frequency.

A practical example for 145 MHz using URM75 (velocity factor = 0.66): calculated 1/2 wavelength = 1035mm. 1035 multiplied by 0.66 = 683mm.

It is better to cut the cable a couple of centimeters too long and trim it to the correct length using a Grid Dip Oscillator. Short-circuit the co-ax cable inner to outer at both ends, forming one of them into a small loop. Check the dip occurs at the center frequency you are interested in. If you have difficulty with the GDO at (for example 433 MHz) then open-circuit one end of the balun and check the dip at 1/2 the operating frequency (example = 216.5 MHz). This co-axial balun works equally well at HF but the bandwidth may be a bit narrow and a balun for 1.8MHz would use half a 100 meter roll of cable!!.

Well, this is about enough to get you started playing with baluns. There are many books on the subject, by far the best I have seen is the trusty ARRL Radio Amateurs Handbook. So, have fun and don't get your lips burned, de HARRY, Upplands Vasby, Sweden.

# Why cell phones are still grounded

By Mike Elgan: Computerworld April 06, 2007

It's because phones interfere with airplane electronics, right? Wrong. How many times have you heard this?

No, actually. The risk posed by cell phones to airplane equipment is unknown, and will remain unknown for as long as possible.

Phones are banned for two official reasons:

Cell phones "might" interfere with the avionics of some airplanes "might" cause problems with cell tower systems on the ground. Both of these risks are easily tested, yet neither the Federal Aviation Administration (FAA) nor the Federal Communications Commission have been able to get a definitive answer in the past 20 years as to whether phone calls in flight cause these suspected problems. (The FAA is responsible for the flight safety portion of all this, and the FCC is responsible for the cell tower part.)

The government's dirty little secret is that it cultivates uncertainty about the effects of phones in airplanes as a way to maintain the existing ban without having to confront the expense and inconvenience to airlines and wireless carriers of allowing them.

**Why airlines want the ban.** The airlines fear "crowd control" problems if cell phones are allowed in flights. They believe cell phone calls might promote rude behavior and conflict between passengers, which flight attendants would have to deal with. The airlines also benefit in general from passengers remaining ignorant about what's happening on the ground during flights, including personal problems, terrorist attacks, plane crashes and other information that might upset passengers.

One way to deal with callers bothering non-callers would be to designate sections of each flight where calling is allowed -- like a "smoking section." But the ban is easier. Also: If real testing were done, and the nature of the problem fully understood, it would become obvious that airplanes could be designed or retrofitted with shielding and communications systems that would enable safe calling through all phases of flight. But that would cost money. The ban is cheaper.

However, the airlines know that some kind of plane-to-ground communication is coming, and they want to profit from it. Simply allowing passengers to use their own cell phones in flight would leave the airlines out of the profit-taking. Airlines would prefer that phones be banned while they come up with new ways to charge for communication, such as the coming wave of Wi-Fi access. Meanwhile, the ban is potentially more profitable.

**Why carriers want the ban.** Cell phone and tower designs are based on the assumption that at any given time, only a few cell towers will be close to any specific phone. So any given tower will use different channels than those used by other towers closest to it, but will use the same channels as towers farther away. However, when a phone is used in an airplane, it might have roughly equal access to two or more towers that use the same channels, which confuses the carriers' computer systems. This situation might result in interrupted calls, reduced system capacity and other problems. Of course, this could be fixed in any number of ways, including an overhaul of the software used to manage calls between towers, but the fix would cost money. The ban is cheaper.

**Why the government wants the ban.** Cell phones and other electronics vary in how much they could interfere with avionics. If proved that some devices do cause problems, all gadgets would have to do extra certification testing, which the Government does not want to spend the money to do. The ban is cheaper.

Also: No FCC or FAA chairman wants to sign off a change in the rules because if a cell phone does cause either an airplane crash or a cell tower computer system crash, they don't want to be blamed. Keeping the ban is the safe decision for the politically ambitious. The ban is easier.

**What are the facts?** DVD players, laptops, portable game machines, CD players, MP3 players all radiate energy, and theoretically could cause interferences with GPS systems, comms equipment and the airplane's interaction with distant navigational systems. U.S. airlines alone carry on average some 2 million passengers per day. If just 1% of these passengers accidentally or deliberately leave their cell phones on, that means some 20,000 cell phones remain on during flights every single day. Despite this, no crash has ever been definitively attributed to cell phone or gadget interference.

Many headsets used by private pilots come with jacks for using them with cell phones. The manufacturers say they're for use on the ground only. But many private pilots use them in the air without incident.

Cell phones are used in airplanes every day, and no crash has ever been definitively attributed to cell phone or gadget interference. However, a Carnegie Mellon University study conducted some four years ago found that portable electronics interfere with airplane systems -- especially GPS -- even more than previously feared.

The Radio Technical Commission for Aeronautics (RTCA), a nonprofit corporation that advises the FAA, studying the effect of phones on avionics. The RTCA is also looking at technologies that would minimize any disruption, including the use of ultra-wideband frequencies and extremely low-power cellular phone systems. They're predicting a definitive answer to all this, but don't hold your breath.

Just this week, the FCC officially dropped its inquiry into lifting an existing ban on using cell phones during commercial flights.

The FCC said after the ruling that "given the lack of technical information in the record upon which we may base a decision, we have determined at this time that this proceeding should be terminated."

So the ban remains in place because the government can't seem to come up with definitive answers.

But does that even matter? Interference problems could be overcome with well-understood techniques of shielding, reprogramming and other technology designed to facilitate safe calls.

(When I say "we," I mean we Americans. In Europe, they're working on both legalizing and facilitating calls on airplanes.)

**What's wrong with the ban?** The government's reasoning for banning cell phones in airplanes is weak, lame and evasive. Don't buy the government's bull about electronic interference. The truth is that the ban is cheaper and easier for airlines, carriers and the government than mustering the political will and leadership to make in-flight cell calls a reality.

Here's another problem with the government's abdication of responsibility on this question: Either phones and other gadgets can crash airplanes or they can't. If they can, then we've got a serious problem on our hands, and airplanes need to be upgraded to protect the public safety.

What's to stop terrorists from testing various gadgets, finding the ones with the highest levels of interferences, then turning on dozens of them at some crucial phase of flight, such as during a landing in bad weather? If gadgets can't crash planes, then the ban is costing billions of hours per year of lost productivity by business people who want to work in flight.

For the government to avoid knowing the answer is incredibly irresponsible. Clearly, using cell phones is a public benefit, not to mention a business benefit. Shouldn't the airlines and the regulatory agencies figure out how to make that happen?

We can put a man on the moon -- and let him chat with his friends in Houston for the whole trip. Surely, we can solve the problems associated with in-flight cell calls.

(Mike Elgan is a technology writer and former editor of Windows Magazine. He can be reached at [mike.elgan@elgan.com](mailto:mike.elgan@elgan.com) or his blog: <http://therawfeed.com>)

# ORIGINS OF THE PRINTED CIRCUIT

By F H Flanter ZS1FD, 33 Edinburgh Place, Tkai 7945

*Today's wave of electronic equipment used everywhere is quite unthinkable without the use of the printed circuit. Very little is known about its origins or its inventor, so it is of interest to go back to the beginning of this technique.*

It was in the early thirties of this century that mains-operated "radios" started to appear on the market, doing away with dry batteries for HT and accumulators for the filaments and the required chargers. This led to an explosion in the quantity being manufactured. The price of components at the period was more or less fixed, but the labour costs made up the larger proportion of the manufactured articles, hence the search for a method which would bring reduction in just this field, which consisted mainly of the cost of wiring and testing for faults, not to mention cold joints, etc.

## PATENTS

All patents in the "radio" field in Europe were held by Telefunken, who did no actual manufacturing but licensed the various producers to use their patents. At around this time, in the early 30s, Telefunken developed a special valve, called the Arcotron after Baron von Arco, the head of the laboratories. To reduce manufacturing costs it was radically different from the standard types in as much as it had no grid. Instead a thin layer of aluminium was sprayed on the glass envelope, controlling the electron flow between cathode and plate in a capacitive manner.

## SPECIAL CIRCUIT

A special circuit was developed, what we would consider a TRF today, using the same valve both as RF, first audio and output stage, delivering some 300 mW,

enough to drive the home loudspeakers of the time. In addition, a wiring technique had been developed consisting of brass strips, coated with an adhesive on one side, fastened to strips of bakelite sheet ("Pertinax") to which components were then soldered.

## MURPHY MAKES HIS APPEARANCE

A number of factories were licensed to use the Arcotron and the associated manufacturing process and all seemed set for reducing costs to an absolute minimum. However, Murphy entered the scene in a very powerful manner: Because of the way in which the electron stream inside the valve was controlled by varying the charge on its outside, it would also respond to any radiation from other sources, such as light switches, even if they sparked in the smallest way.

## BLOCKED RECEIVER

The result would be a blocked receiver! Production stopped immediately and the various licensed companies sued Telefunken for an enormous amount for lost production. In fact, during that year (1931?) no new models appeared on the market. The chassis so far produced appeared on the surplus market and today is a collector's item in Europe.

## END OF FIRST ATTEMPT

That then was the end of the first attempt to replace hand-wiring by a different cost-saving and more reliable method, since no manufacturer wanted anything further to do with the Telefunken method. It was left to Paul Eisler, who recently died at age 85, to translate the idea into a practical

application without which virtually no large scale electronic production would be possible.

## SIMPLE WORKING MODEL

Paul Eisler was born in Vienna in 1907 and arrived in Britain in 1936 as a refugee from Nazi persecution. He found a job as technician with the Odean claim of cinemas. He had presented a simple working model of the present-day printed circuit to the Plessey Company but it was rejected "in favour of wiring done by girls who are cheaper and more flexible". However, the growing demand for electronic devices in the Second World War gave Eisler the opportunity to revert to the printed circuit and his foil method of production. He joined an established firm of printers whose premises had been bombed out and who saw in the printed circuit a means of re-establishing themselves. Eisler was appointed head of the instrument division after having been persuaded to assign to them all his future patents for the princely sum of One Pound Sterling!

## NO INTEREST

He demonstrated the first radio set incorporating printed circuits to engineers and military personnel all over Britain and America, but no companies or government departments gave his idea a trial. Later Eisler became technical director of the Technograph company with what seemed enough financing. However this arrangement failed and Eisler resigned in 1957 to devote himself to other fields.

The American rights to the printed circuit patents were given away for a "paltry sum" and the British originators did not benefit from the world-wide use of the product. Eisler's invention was the basis of the integrated circuit chip without which modern electronics would be unthinkable.

ZS

## Long Term HF Propagation Prediction for Sept 2007 (courtesy Vince ZS6BTY)

### DX Operating

The graph shows the 4000 km maximum useable frequency (MUF) to the East, North, West and South from Pretoria for the first hop using the F2 layer.

### Local Operating

The F2 critical frequency (foF2) is the maximum frequency that will reflect when you transmit straight up. E-layer reflection is not shown.

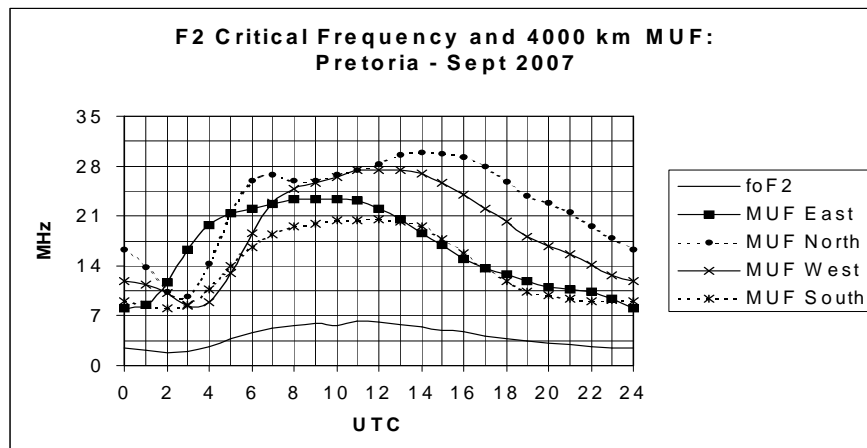

# Australian rams phone masts with APC

extracted from zdnet 16 July 2007

An ex-communications employee of the Australian army destroyed seven transmitter masts with a stolen Armoured Personnel Carrier (APC). He claimed that radiation damaged his brain and was referred for psychiatric examination.

45-Year old John Robert Patterson made this claim. He stole a British APC that he himself had helped to repair the previous year and flattened the masts at three transmitting sites belonging to Optus and Telstra.

Both spokesmen of the companies declared that damage was minimal and that other masts had compensated for the reduction of signal.

Reacting to the incident, the Australian Vice-Chairman of the Mobile Telecommunications Association (AMTA) Chris Althaus, said that the effects of this type of radiation is minimal. The output levels are much lower than domestic equipment such as magnetrons or AM radios.

Greg Morris, the forgiving owner of the APC will have to repair it out of his own pocket. "He had no problem with me personally but needed the APC to solve his own problem"



## WHY NOT MAKE USE OF OUR EASY PAYMENT PLAN

*when purchasing any piece of Radio gear. A cash deposit of 15% puts one of these superb units in your Ham Shack and the balance is payable in monthly instalments over 12, 18 or 24 months.*

Introducing

## GONSETS NEW MODEL GSB100

**A complete self-contained SSB/CW/AM Transmitter for operation on the 80, 40, 20, 15 and 10 metre bands**

**£279. 10. 0**

**or £42 down and £11. 18. 0 per month**

1959

### THE AMATEUR.

"Who's that stranger, Mother dear?

Look, he knows us; ain't he queer?"

"Hush, my own! Don't talk so wild.

That's your Father, dearest child."

"That's my Father? No such thing!

Father died away last Spring."

"Father didn't die, you dub!

Father joined an amateur club.

Now the club is closed, so he

Has no place to go, you see;

No place left for him to roam,

That is why he's coming home.

Kiss him, he won't bite you, child;

All them Ham-guys look wild!"

H. GILLIS, ZS1SF.

(With apologies to my XYL.)

## WERNER BROS.

(PTY.) LTD.

P.O. Box 32 112 Oxford St.  
EAST LONDON

Specialists in the

OVERHAUL and ALIGNMENT  
of all makes of

COMMUNICATIONS RECEIVERS

TRANSMITTERS and AMPLIFIERS

built to specification  
Satisfaction guaranteed

Under personal supervision of  
ZS2CK

who welcomes your enquiries